



DIGITALINX

VALUE-ENGINEERED DIGITAL SOLUTIONS

DL-HDE100-H2 Quick Install Guide



This guide is for quick installation only.
For complete owners manual go to www.libav.com or use a QR reader to access the manual via QR code below.



Scan QR Code with your Smart-phone or Tablet



A SUBSIDIARY OF WESCO DISTRIBUTION, INC.
11675 Ridgeline Drive
Colorado Springs, CO
80918

Rev 191119

Phone: 719-260-0061
Toll-Free: 800-530-8998
Fax: 719-260-0075

Product Overview

The DigitaLinx DL-HDE100-H2 HDBaseT extender set extends HDMI audio, video as well as control up to 100m / 330' using a single Category 6 cable. Supports HDMI 2.0a, HDR10 and HDCP 2.2 as well as Dolby Atmos and DTS:X audio formats. Control extension supports bidirectional IR, Ethernet pass through and RS232 pass through.

The DigitaLinx DL-HDE100-H2 can transport HDMI data rates up to 18Gbps up to 100 meters. The system enables high data rates by utilizing visually lossless compression at a 2:1 data compression rate when the signal surpasses 10Gbps, anything under 10Gbps will never be compressed.

Built-in surge protection and diagnostic LEDs ensure hassle-free and robust installations. Flexible power design allows the units to be powered at either the TX or RX end, and only one power supply is required to power the set. The 12 volt power supply is secured with a screw-on connector to prevent the power from being accidentally disconnected.

The DL-HDE100-H2 is sold only as a set. The individual transmitter and receiver are not compatible with other HDBaseT devices due to proprietary PoE circuitry.

Package Contents

- DL-HDE100-H2 Extender Set
- Quick Install Guide
- (1) IR Emitter
- (1) IR Broadband Receiver (30-50KHz)
- (1) DC12V 2A power supply with US, UK, EU and AU power adapter plugs
- (4) Mounting clips with mounting screws
- (1) IR-AC IR coupler cable
- (2) Phoenix 3.5mm 3 pin male connectors

Transmitter View

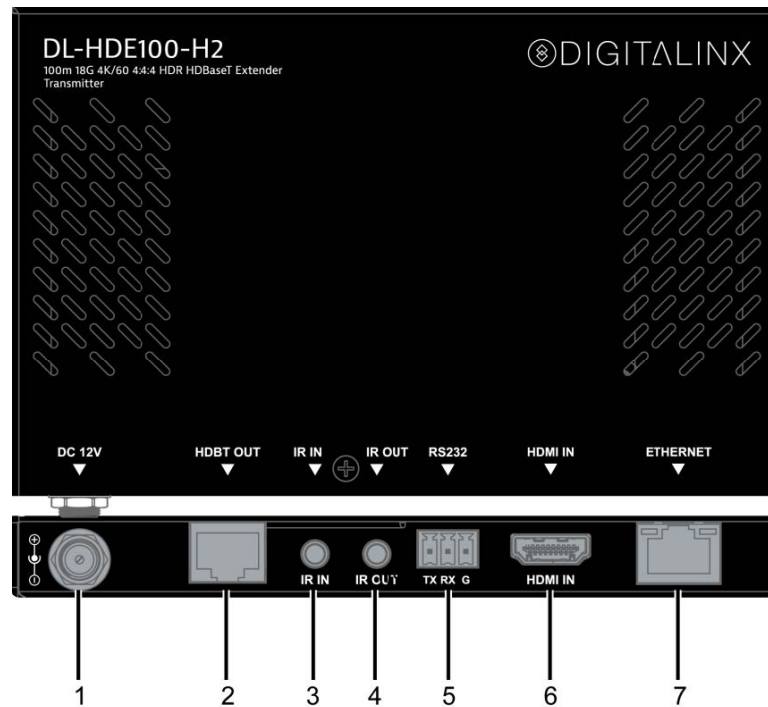

1. **DC 12V** - Locking power supply port (transmitter)
2. **HDBT OUT** - HDBaseT output; RJ45 connection
3. **IR IN** - 3.5mm IR input port for connection to IR receiver or 3rd party IR system
4. **IR OUT** - 3.5mm IR output port for connection to IR emitter
5. **RS232** - 3 pin Phoenix connector port for passing RS232 control to transmitter location
6. **HDMI IN** - HDMI input port for connection to HDMI video source
7. **ETHERNET** - RJ45 port for passing Ethernet to receiver / display location

Front Panel LED States for Transmitter / Receiver

POWER (RED)- Solid when device is powered ON

STATUS (BLUE)- When blinking the device is working properly

HDCP (BLUE) - Solid when HDMI signal is encrypted; blinking when non-HDCP protected content is transmitted; OFF when no content is being transmitted

LINK (GREEN)- Solid when successful link between transmitter and receiver is established; off or blinking indicates a physical link error

Receiver View

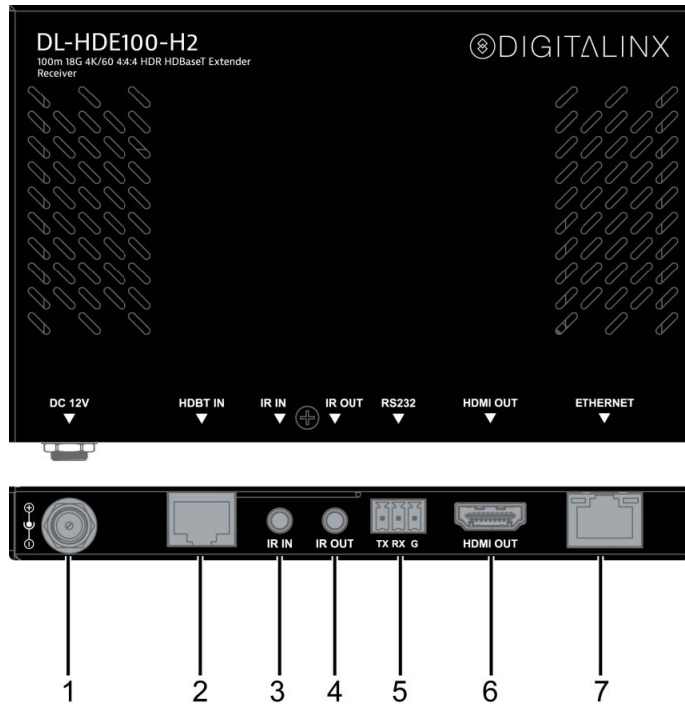

1. **DC 12V** - Locking power supply port (transmitter)
2. **HDBT IN** - HDBaseT input; RJ45 connection
3. **IR IN** - 3.5mm IR input port for connection to IR receiver or 3rd party IR system
4. **IR OUT** - 3.5mm IR output port for connection to IR emitter
5. **RS232** - 3 pin Phoenix connector port for passing RS232 control to transmitter location
6. **HDMI OUT** - HDMI output port for connection to HDMI display
7. **ETHERNET** - RJ45 port for passing Ethernet to transmitter location

Front Panel LED States for Transmitter / Receiver

POWER (RED)- Solid when device is powered ON

STATUS (BLUE)- When blinking the device is working properly

HDCP (BLUE) - Solid when HDMI signal is encrypted; blinking when non-HDCP protected content is transmitted; OFF when no content is being transmitted

LINK (GREEN)- Solid when successful link between transmitter and receiver is established; off or blinking indicates a physical link error

Connectivity Instructions

1. Verify all components included with the extender set are present before installation.
2. If the extenders are going to be permanently mounted to a surface, attach the included mounting brackets with the supplied screws.
3. Turn off power and disconnect the audio/video equipment by following the manufacturer's instructions.
4. Connect Category 6 or greater twisted pair cable with RJ45 connectors between the DL-HDE100-H2 transmitter and the receiver. TIA/EIA-568B straight-through wiring connections must be used with all HDBaseT extenders.
5. Connect an HDMI cable and any desired IR control, RS232 and Ethernet accessories between the display and the DL-HDE100-H2 receiver.
6. Connect an HDMI cable and any desired IR control, RS232 and Ethernet accessories between the source and the DL-HDE100-H2 transmitter.
7. Connect the included power supply to the DL-HDE100-H2 transmitter or receiver and lock the power supply to the power connector by twisting the locking collar clockwise.
8. Power on attached audio/video devices.

Passing IR Signals:

The DL-HDE100-H2 is capable of passing IR signals between 33 and 50 KHz. To prevent damage to any of the electronics, the extenders should be powered off while inserting or removing any IR components. Inserting an IR transmitter into the IR IN port may damage the IR circuit for that extender.

IR OUT: The IR transmitter (IR emitter) must be plugged into the IR OUT port.

IR IN: The IR receiver (IR eye) must be plugged into the IR IN port.

To pass 3rd party IR system signals through the DL-HDE100-H2, such as a control system, connect the TS connector of the IR-AC coupling cable (provided) to the IR output port of the control system and connect the TRS connector of the IR-AC cable to the IR IN to either transmitter or receiver of the DL-HDE100-H2

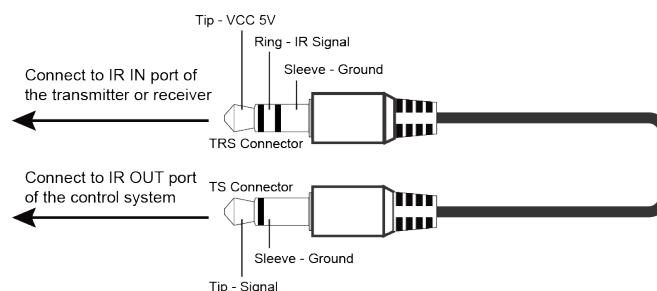

Cabling Wiring Requirements

HDBaseT Cabling

To ensure proper performance of the DL-HDE100-H2, it is recommended that you use solid core, shielded Category 6 F/UTP cabling at a minimum. Category 5e F/UTP may perform well but may not support power over HDBaseT reliably over longer distances.



When using shielded category cabling *ALWAYS*...

-use shielded connectors
-properly ground the category cable

For optimized HDBaseT performance use the following Liberty Wire and Cable branded cabling;

- UHD @ 70m / 230' Category 6 plenum; **24-4P-P-L6SH**
 Category 6A plenum; **24-4P-P-L6ASH**

- UHD @ 100m / 330' Category 6 NON-plenum; **24-4P-L6SH**
 Category 6A NON-plenum; **24-4P-L6ASH**

Twisted Pair Wiring

Use TIA/EIA-568B wiring for Category 6 connection between send and receive units.

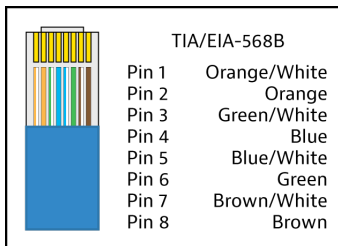

RS232 Wiring

Connect the controller or device RXD signal to Tx on the DL-HDE100-H2 extender.
 Connect the controller or device TXD signal to Rx on the DL-HDE100-H2 extender.

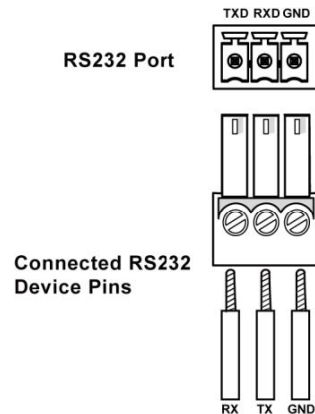
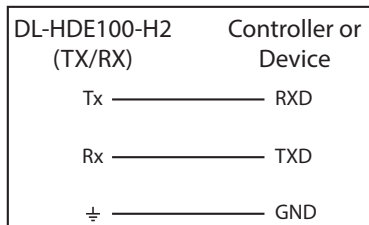

Technical Specifications

Supported Audio and Video	
Video Compliance	HDMI 2.0a, HDCP 2.2, and CEC (Consumer Electronics Control)
Input / Output Resolution Support	SMPTE: Up to 4096x2160@60Hz (4:4:4 chroma sub-sampling / 8 bit deep color) VESA: Up to 1920x1200
Maximum Pixel Clock	600MHz
Embedded Audio	Up to PCM 8 channel, Dolby Atmos, DTS: X, Dolby TrueHD, DTS-HD Master Audio, Dolby Digital and DTS
IR Carrier Frequency Range	33-55kHz at 5 volts
RS232 Baud Rate	Up to 115200 baud
HDBaseT Signal Characteristics	
Maximum Distance	1080p: 100 meters / 330 feet 4K: 70 meters / 230 feet
Cable Requirements	Solid core F/UTP Category 6 cable or greater with TIA/EIA-568B crimp pattern
Bandwidth	18 Gbps
Chassis and Environmental	
Dimensions (WxHxD)	TX / RX- 150mm x 15.8mm x 95.2mm (5.90" x 0.62" x 3.75")
Operating Temperature (Environment)	TX/RX- 0° to +45° C (+32° to +113° F)
Operating Humidity (Environment)	TX/RX- 10% to 90%, Non-condensing
Product Weight	TX/RX- 0.26kg / 0.57 lbs
Power	
Maximum Power Consumption	17 watts (TX)- when receiver is powered by transmitter 16 watts (RX)- when transmitter is powered by receiver
Power Supply Input Voltage	100-240V AC at 50-60 Hz
Power Supply Output Voltage	DC 12V 2A
ESD Protection	±8kV(Air-gap discharge)/ ±4kV(Contact discharge)
Surge Protection	Voltage: ±1 kV
Regulatory	CE, FCC
Other	
Standard Warranty	5 Years
Included Items	(1) Transmitter, (1) Receiver, (1) Quick Install Guide, DC 12V Power Supply with US, UK, EU and AU adapters, (1) IR Transmitter, (1) IR Receiver, (1) IR-AC IR coupler cable, (4) Mounting Brackets, Mounting Screws and (2) Phoenix 3.5mm 3 pin male connectors

Thank you for your purchase.

For Technical Support please call our toll free number at
800-530-8998 or email us at supportlibav@libav.com

www.libav.com

Digitalinx is a brand of:



LIBERTY
AV SOLUTIONS

11675 Ridgeline Drive
Colorado Springs, Colorado
80921 USA
Phone: 719-260-0061
Fax: 719-260-0075
Toll-Free: 800-530-8998